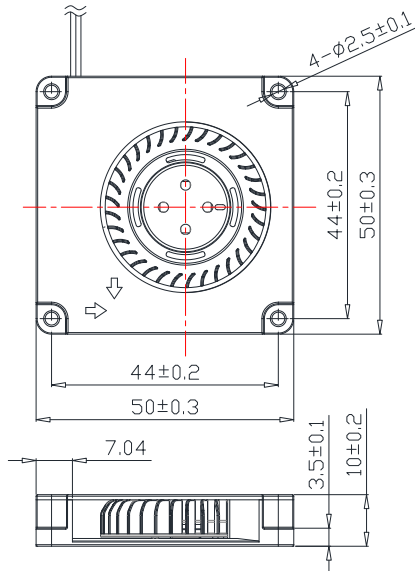
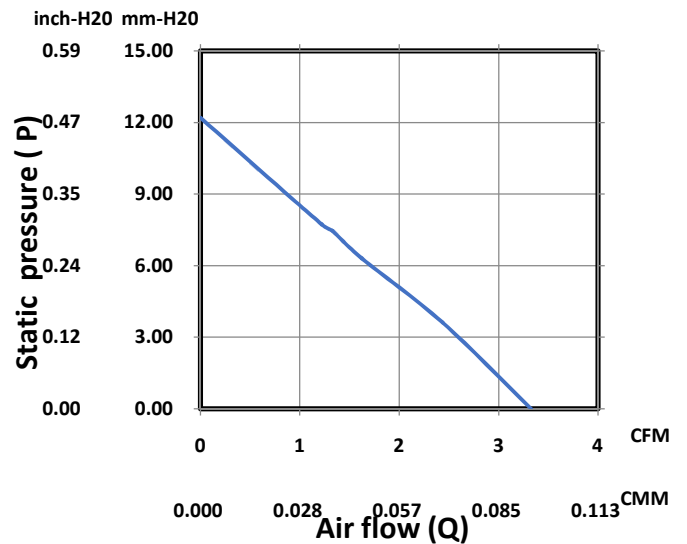

**50 x 50 x 10 mm Series**
**Rev. I**
**Dimensions**

**Performance Curve**

**General Specification**

Frame	PBT 94V-0
Impeller	PBT 94V-0
Lead Wire	UL1007 AWG30
Storage Temperature	-20°C ~ 80°C
Operating Temperature	-10°C ~ 75°C
Mass	17 grams

**Bearing Type**

- CeraDyna A
- CeraDyna C
- Ball Bearing
- Sleeve Bearing
- Fluid Dynamic Bearing

**Function Options**

- Auto Restart
- Frequency Generator
- Rotation Detect
- Temperature Control
- PWM Control

\*Air exhaust over struts. Rotational direction CCW looking at rotor

\*The motor is with electronic protection against reverse polarity. The motor only operates when the polarity is correct.

**Specifications**

Model No.	Rated Voltage (V)	Rated Current (A)	Input Power (W)	Nominal Speed (RPM)	Airflow (CFM)	Static Pressure (Inch-H2O)	SPL (dB A)
FW0550-DP2XXA	5	0.3	1.5	6600	3.33	0.48	35.6
FW1250-S22XXA	12	0.11	1.32	6600	3.33	0.48	35.6

\*All readings are typical value at rated voltage.

\*Please refer to **PART NUMBER SYSTEM** for bearing type and part number "XX" designation.

\*Please specify revision number when ordering.