

25 x 25 x 10 mm Series

Rev. II

Dimensions

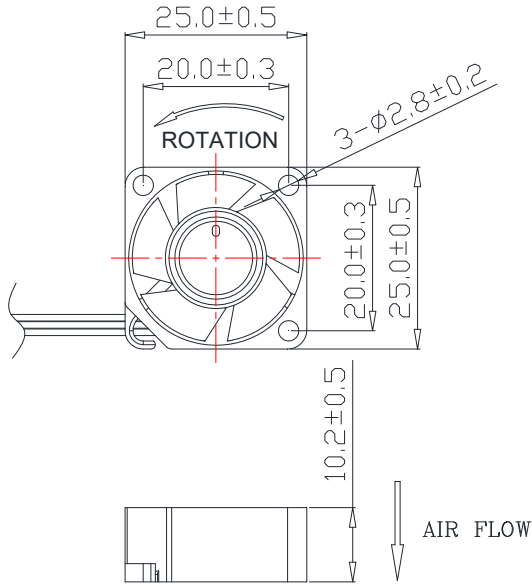

Performance Curve

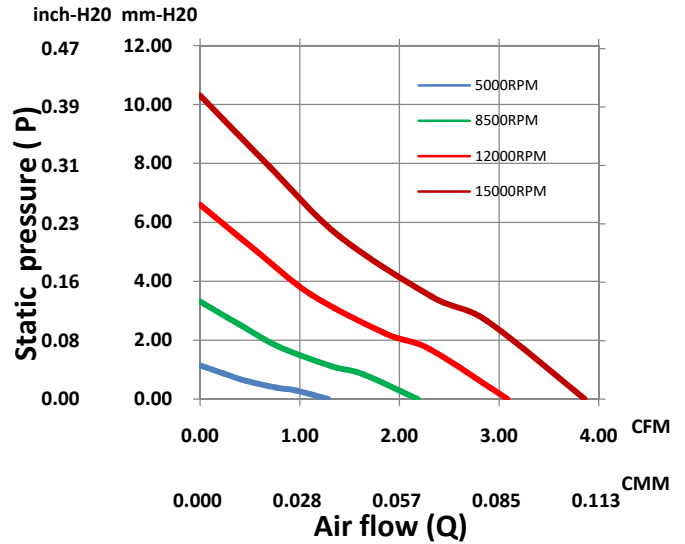

General Specification	
Frame	PBT 94V-0
Impeller	PBT 94V-0
Lead Wire	UL3302 28AWG
Storage Temperature	-40°C ~ 80°C
Operating Temperature	-15°C ~ 75°C
Mass	TBD

Bearing Type	Function Options
<input type="radio"/> CeraDyna A	<input checked="" type="radio"/> Auto Restart
<input type="radio"/> CeraDyna C	<input checked="" type="radio"/> Frequency Generator
<input checked="" type="radio"/> Ball Bearing	<input type="radio"/> Rotation Detect
<input checked="" type="radio"/> Sleeve Bearing	<input type="radio"/> Temperature Control
<input type="radio"/> Fluid Dynamic Bearing	<input checked="" type="radio"/> PWM Control

*Air exhaust over struts. Rotational direction CCW looking at rotor

*The motor is with electronic protection against reverse polarity. The motor only operates when the polarity is correct.

Specifications

Model No.	Rated Voltage (V)	Rated Current (A)	Input Power (W)	Nominal Speed (RPM)	Airflow (CFM)	Static Pressure (Inch-H2O)	SPL (dB A)
FD0525-X01XXA	5.0	0.15	0.75	15000	3.85	0.41	30.5
FD0525-X11XXA	5.0	0.10	0.5	12000	3.08	0.26	25.0
FD0525-X21XXA	5.0	0.06	0.3	8500	2.18	0.13	18.9
FD0525-X31XXA	5.0	0.02	0.1	5000	1.28	0.05	8.5
FD1225-X01XXA	12.0	0.07	0.84	15000	3.85	0.41	30.5
FD1225-X11XXA	12.0	0.05	0.6	12000	3.08	0.26	25.0
FD1225-X21XXA	12.0	0.03	0.36	8500	2.18	0.13	18.9
FD1225-X31XXA	12.0	0.02	0.24	5000	1.28	0.05	8.5

*All readings are typical value at rated voltage.

*Please refer to **PART NUMBER SYSTEM** for bearing type and part number "XX" designation.

*Please specify revision number when ordering.